



STAFF REPORT: NEW EMISSION STANDARDS,
FLEET REQUIREMENTS, AND TEST PROCEDURES
FOR FORKLIFTS AND OTHER INDUSTRIAL EQUIPMENT



Date of Release: March 3, 2006
Scheduled for Consideration: April 20, 2006

Regulation for Large Spark-Ignition (LSI) Engine Forklifts and Other Industrial Equipment

SMAQMD/Clean Cities Clean Technologies Forum

July 16, 2009

California Environmental Protection Agency



Air Resources Board

Overview

- ◆ What is LSI
- ◆ The LSI Regulation
- ◆ Fleet Average
 - Applicability
 - Forklift Definition
 - Requirements
 - Calculations
 - Exemptions & Exclusions
 - Agricultural Compliance
- ◆ Compliance Extensions
- ◆ Recordkeeping
- ◆ Advisories and Fact Sheets
- ◆ Enforcement
- ◆ Contact Information



What is LSI?

- ◆ Greater than 25 horsepower and 1 liter
- ◆ Automotive technology
- ◆ Gasoline, propane, and CNG fuel
- ◆ Not diesel
- ◆ Not portable equipment

The LSI Regulation

- ◆ First adopted in 1998
 - 3.0 gram per brake horsepower-hour (g/bhp-hr) standard phased in between 2001 and 2004
 - 75 percent emission reduction vs. uncontrolled
- ◆ Amended in May 2006
 - 4 components
- ◆ New Engine Standards and Test Procedures
 - 2.0 g/bhp-hr in 2007; 0.6 g/bhp-hr in 2010
 - 95 percent emission reduction vs. uncontrolled
- ◆ Retrofit Kit Verification Procedures
- ◆ Fleet Average Requirements

Fleet Average Requirements

- ◆ Intent
 - Promote retrofit or replacement of uncontrolled engines
- ◆ Applicability
 - 4 or more forklifts, tow tractors, sweeper/scrubbers, or pieces of airport ground support equipment (GSE)

Forklift Definition

“Forklift” means:

- ◆ an electric Class 1 or 2 rider truck, or
- ◆ an LSI engine-powered Class 4 or 5 rider truck
- ◆ as defined by the Industrial Truck Association (<http://www.indtrk.org>)

- ◆ Electric Class 3 trucks are not forklifts for the purposes of the LSI Fleet Regulation

Class 1 Forklifts (4 subclassifications)

- ◆ Lift Code 1
 - Counterbalanced Rider
 - Stand Up

- ◆ Lift Code 4
 - Three Wheel
 - Sit Down

- ◆ Lift Code 5
 - Counterbalanced Rider
 - Cushion tires
 - Sit Down

- ◆ Lift Code 6
 - Counterbalanced Rider
 - Pneumatic/ Cushion tires
 - Sit Down

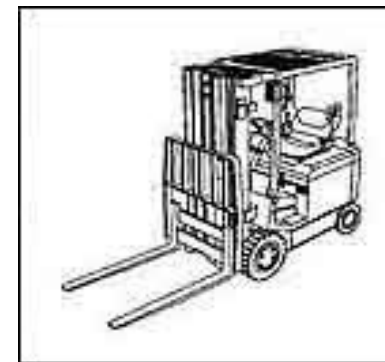
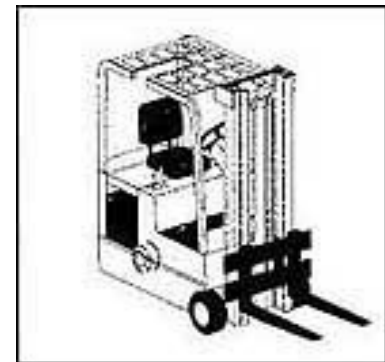

Class 2 Forklifts (5 subclassifications)

- ◆ Lift Code 1
 - High Lift Straddle
- ◆ Lift Code 2
 - Order Picker
- ◆ Lift Code 3
 - Reach Type Outrigger
- ◆ Lift Code 4
 - Side Loaders, Turret Trucks, Swing Mast and Convertible Turret/Stock Pickers
- ◆ Lift Code 6
 - Low Lift Pallet and Platform (Rider)

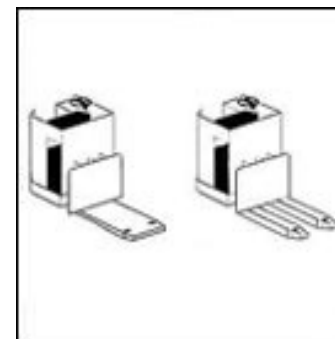
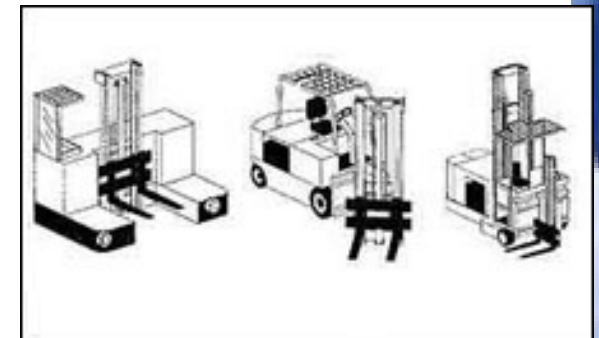
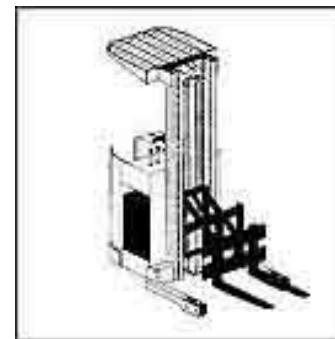
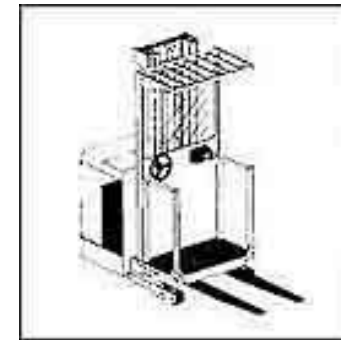
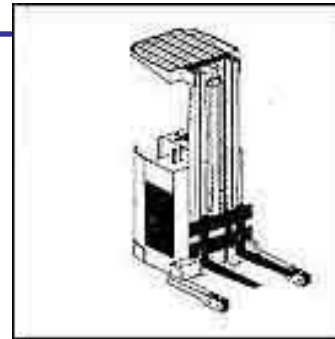

Class 4 and 5 Forklifts

- ◆ Class 4; Lift Code 3
 - Counterbalanced Rider
 - Cushion tire

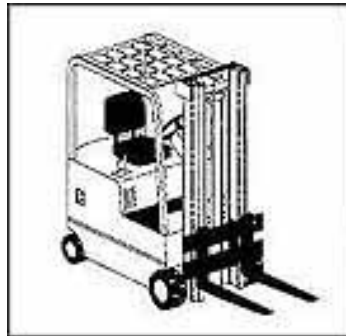

- ◆ Class 5; Lift Code 4
 - Counterbalanced Rider
 - Pneumatic tire



Class 3 Forklifts (Lift Codes 1 - 4)

- ◆ Lift Code 1
 - Low Lift Platform

- ◆ Lift Code 2
 - Low Lift Walkie Pallet

- ◆ Lift Code 3
 - Tractors (Draw Bar Pull <999 pounds)

- ◆ Lift Code 4
 - Low Lift Walkie/Center Control

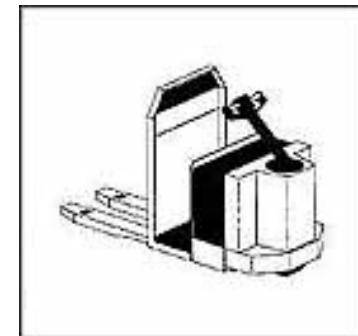
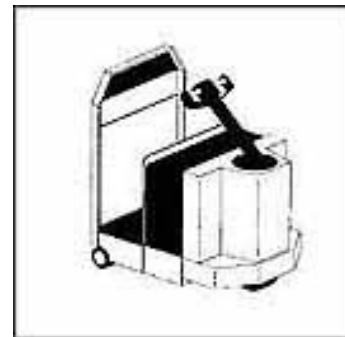
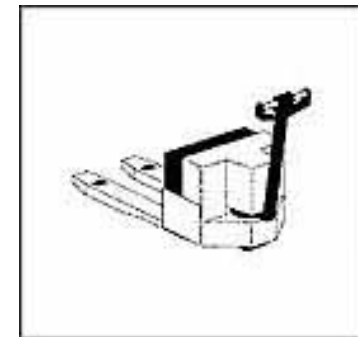
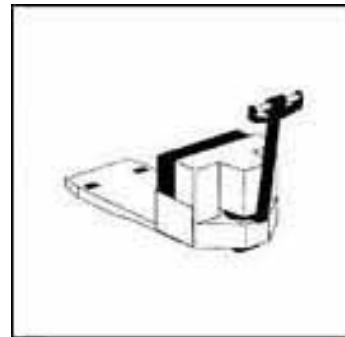

Class 3 Forklifts (Lift Codes 5 - 8)

- ◆ Lift Code 5
 - Reach Type Outrigger

- ◆ Lift Code 6
 - High Lift Straddle

- ◆ Lift Code 7
 - High Lift Counterbalanced

- ◆ Lift Code 8
 - Low Lift Walkie/Rider Pallet

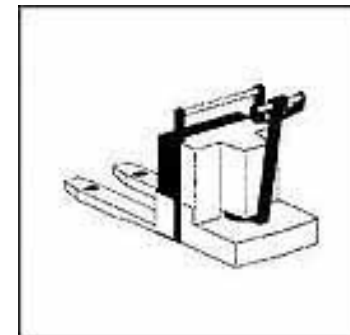
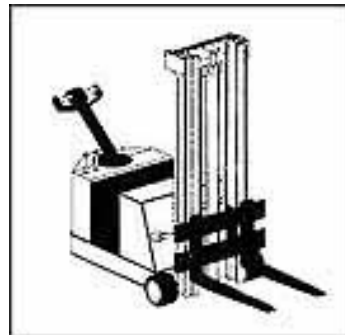
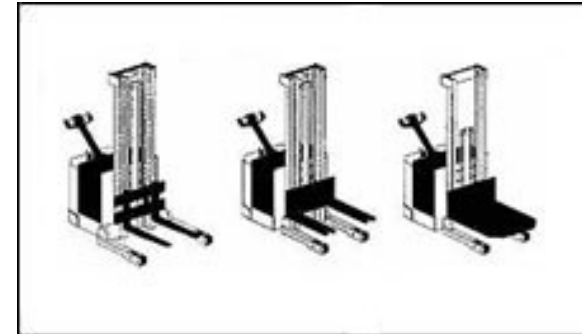
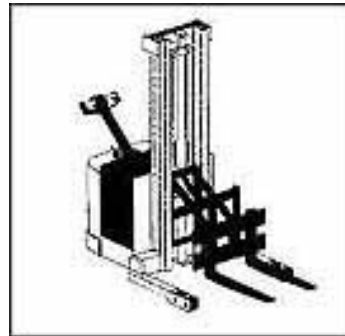

Fleet Average Requirements

◆ Standards

**Fleet Average Emission Level in Grams HC+NO_x per kilowatt-hour
(brake horsepower-hour)**

LSI Fleet Type	Number of units	By 1/1/2009	By 1/1/2011	By 1/1/2013
Large fleet – forklift component	26 +	3.2 (2.4)	2.3 (1.7)	1.5 (1.1)
Mid-size fleet – forklift component	4-25	3.5 (2.6)	2.7 (2.0)	1.9 (1.4)
Non-forklift fleet	N/A	4.0 (3.0)	3.6 (2.7)	3.4 (2.5)

Calculating the Fleet Average

- ◆ Not based on hours of use, horsepower, or emission factors
- ◆ Is a straight average of certification/verification standards and uncontrolled emission rates
 - Pre-2000 and uncontrolled 2001-2004 MY engines
 - 16.0 g/kW-hr HC+NO_x
 - Controlled 2001-2004 and all 2005-2006 MY engines
 - 4.0 g/kW-hr HC+NO_x
 - 2007 MY engines
 - 0.8 - 2.7 g/kW-hr as labeled
- ◆ Engine Labels
 - Typically on valve cover

2001 – 2004 Uncontrolled Label

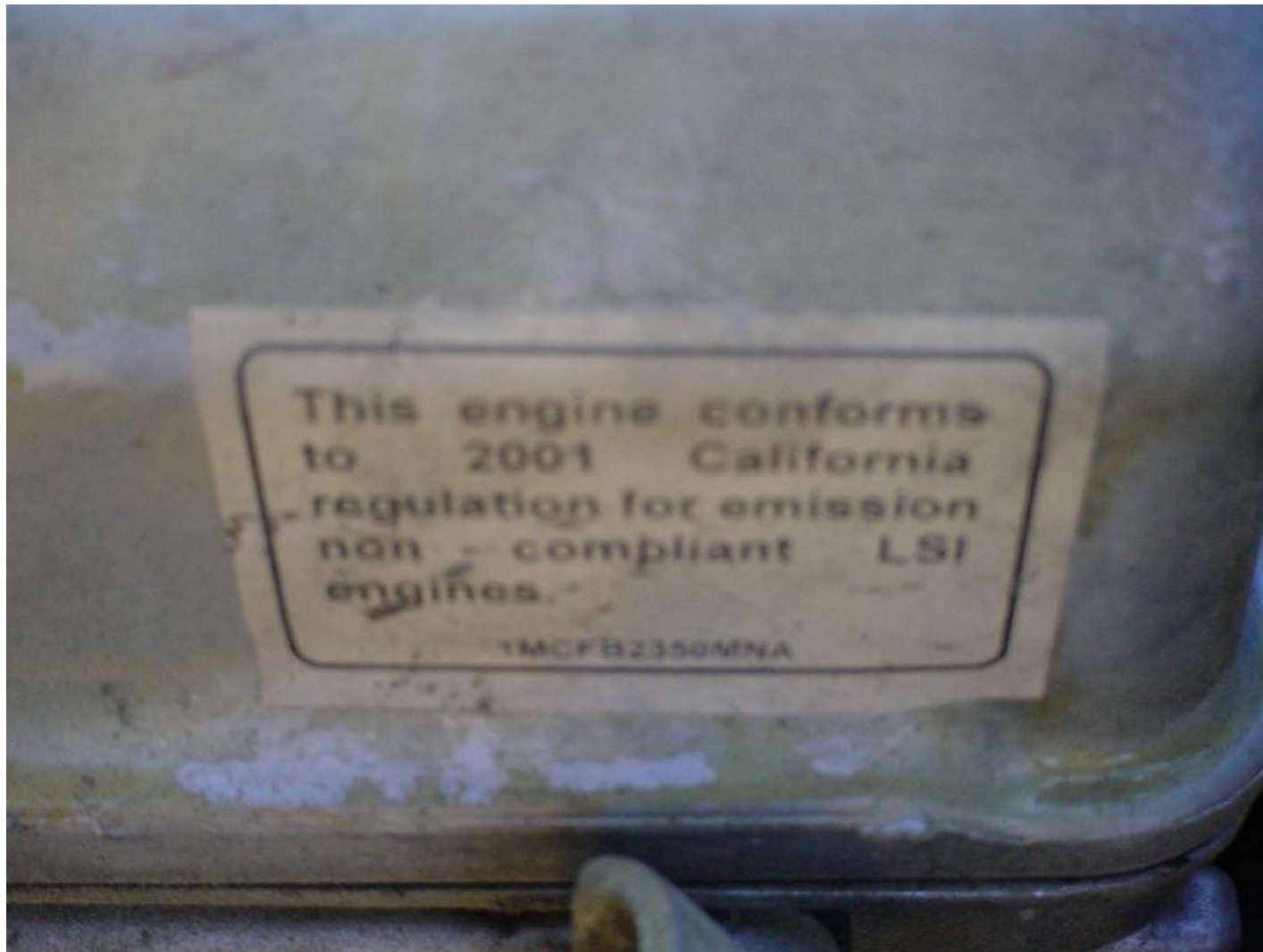

2001 – 2006 Controlled Label



2007 and Newer Label

EMISSION CONTROL INFORMATION

Teleflex[®]GFI

THIS VEHICLE IS EQUIPPED WITH AN ELECTRONIC ENGINE CONTROL SYSTEM. ENGINE IDLE SPEED, IDLE MIXTURE, AND IGNITION TIMING ARE NOT ADJUSTABLE.

THIS ENGINE CONFORMS TO 2007 U.S. EPA AND CALIFORNIA REGULATIONS FOR LARGE NON-ROAD SI ENGINES VARIABLE SPEED APPLICATIONS ONLY

THIS ENGINE IS CERTIFIED TO OPERATE ON LPG
DISPLACEMENT: 2.4L MAXIMUM POWER: 49kW
EXHAUST EMISSION CONTROL SYSTEM: SFI, HO₂S, TWC
ENGINE FAMILY: 7G9XB02.49NP SPARK PLUG GAP: 0.8 - 0.9mm
USEFUL LIFE: 5000 HOURS OR 7 YEARS
EMISSION STANDARD: HC+NO_x 0.8g/kW-hr
CO 20.6g/kW-hr

A7-367

ENGINE BUILD DATE 07/2007

Calculating the Fleet Average

- ◆ No ARB calculator
- ◆ Several 3rd-party calculators:
 - Pape Material Handling:
<http://www.papemh.com/carb.aspx>
 - Raymond Handling Solutions:
http://www.raymondhandlingsolutions.com/Emissions_calculator.html

Fleet Average Exemptions/Exclusions

- ◆ Exemptions
 - Small fleets
 - Some uncontrolled 2003 & 2004 LSI engines
- ◆ Exclusions
 - Limited hours of use (250 or less)
 - Rented 30 or fewer calendar days per year
 - Rental or lease less than one year, provided:
 - no more than 20 percent of fleet, and
 - meets standards (3.0 in '09; 2.0 in '11)

Agricultural Compliance

- ◆ Agricultural Crop Preparation Services
 - Packinghouses, nut hullers and processors, cotton gins, dehydrators, feed and grain mills
 - Other “Postharvest crop activities”
 - NAICS definition for Industry 115114
(<http://www.census.gov/epcd/naics02/def/ND115114.HTM>)

Agricultural Compliance

- ◆ Retrofit owned uncontrolled 1990 and newer forklifts
 - 20 percent by January 1, 2009
 - Remainder by January 1, 2012
- ◆ Rental forklifts rented on or after January 1, 2009
 - No need to address if meet or exceed 3.0 gram standard
 - 2003/04 model year engines excluded until January 1, 2010
- ◆ Leased forklifts
 - No need to address if meet or exceed 3.0 gram standard
 - Exclude leases initiated prior to May 25, 2006 for life of lease or until January 1, 2010, whichever is earlier

Compliance Extensions due to Lack of Retrofit Emission Control Systems

- ◆ Overriding philosophy
 - Retrofitting is only one compliance option
 - Staff will provide as much flexibility as possible
- ◆ Two situations provided for
 - No verified emission controls available – blanket
 - No verified emission controls available – GSE

Recordkeeping and Reporting Requirements

- ◆ The LSI regulation has no reporting requirement.
- ◆ Operators must maintain records
 - A baseline inventory due November 12, 2007
 - Contents: equipment/engine make, model, SN, certification or verification level as demonstrated by a label
 - Propane fuel quality receipts if available
- ◆ Records retained through December 31, 2015
- ◆ Fuel quality records retained for three years
 - Only if obtainable
- ◆ Records may be aggregated at a centralized facility or headquarters

Fact Sheets, Advisories, EOs & FAQ

California Environmental Protection Agency | AIR RESOURCES BOARD

OVERVIEW OF THE

New Emission Standards, Test Procedures, and Fleet Requirements for Large Spark-Ignition (LSI) Engine Forklifts and Other Industrial Equipment

New rules to achieve significant emission reductions and protect public health

On May 25, 2006, the California Air Resources Board (ARB) amended the existing emission standards and test procedures for off-road large spark-ignition (LSI) engine powered equipment to make them more stringent. The ARB also adopted new regulations requiring emission reductions from existing LSI fleets and prescribing verification procedures for LSI retrofit emission control systems.

Why did the ARB staff propose these regulations?

There are more than 90,000 off-road LSI engines in California. Many of these engines have no emission controls and some remain in operator fleets for decades. Just one uncontrolled engine can emit as much hydrocarbon (HC) and oxides of nitrogen (NO_x) in three eight-hour shifts as a new car certified to California's cleanest emission standard does over its entire lifetime. The HC and NO_x combine in the atmosphere to form ground level ozone, which can damage the respiratory tract and worsen asthma symptoms. The LSI Regulation will reduce HC+NO_x emissions by approximately six tons per day, helping California to meet federally imposed clean air standards. If these standards are not met, the federal government could impose economic sanctions on California; for example, federal highway funding could be withheld.

Who must comply with these regulations?

Manufacturers of 25 horsepower or greater (greater than 19 kilowatts) off-road LSI engines must comply with the new engine standards and test procedures and manufacturers of retrofit emission control systems intended for use on LSI engines must comply with the verification procedures.

Individual persons, businesses, and government agencies that own or operate LSI engine-powered fleets in California are subject to the fleet requirements. Out-of-state companies doing business in California are also subject to the fleet requirements.

What types of vehicles are subject to the regulation?

The new engine emission standards apply to manufacturers of any 25 horsepower or greater off-road LSI engine placed in, but not limited to, airport ground support equipment (GSE), forklifts, generator sets, sweeper/scrubbers, industrial tugs (tow tractors), and turf care equipment. A full list of LSI equipment for which the engine standards apply is available at <http://www.arb.ca.gov/msprog/offroad/preempt.htm>

The fleet requirements only apply to forklifts, sweepers/scrubbers, industrial tow tractors, and GSE. Those four categories of equipment represent 94 percent of the total HC and NO_x emissions from LSI equipment and are often found in fleets. Additionally, zero- and near zero-emission alternatives are available for the four equipment categories.

What does the regulation require?

Engine and Retrofit Emission Control System Manufacturers

The regulation establishes more stringent combined HC and NO_x emission certification standards for engine manufacturers. The regulation also establishes verification procedures for manufacturers of retrofit emission control systems. Engine and retrofit emission control system manufacturers will likely employ advanced automotive-style emission control technologies including electronic fuel/air controllers, three-way catalysts, and oxygen sensors to meet the certification and verification standards, respectively.

- ◆ Fact Sheets
 - Available in English and Spanish from website link at end of presentation
- ◆ Advisories
 - 08-01: Delayed enforcement and Purchase Orders
 - 08-02: GSE exclusion
 - 08-03: 3L and controlled engine exclusion
 - 08-04: Forthcoming
 - 19kW electric
 - “Retired” demonstration
 - Use in dealer fleets
- ◆ Executive Orders
 - Verified retrofit kits
- ◆ Frequently Asked Questions
 - Will be continuously updated

Enforcement

- ◆ Performed by ARB and local air districts
 - ARB recently hired additional enforcement staff
- ◆ Conducted in conjunction with other inspections
 - In-use off-road diesel regulation
 - Cargo handling equipment regulation
 - Other mobile and stationary source regulations
- ◆ Penalty
 - Maximum of \$500 per day per piece of equipment

Contacts

- ◆ **Website:** <http://www.arb.ca.gov/lsi>
 - Text of Regulation on pages 13 – 25 of <http://www.arb.ca.gov/regact/lore2006/oalapprovedfro.pdf>
- ◆ **Toll-free number:** **(800) 387-2992**
- ◆ **E-mail:**
 - **Mark Williams (Lead)**
 - mwilliam@arb.ca.gov
 - **Elise Keddie, Zero Emission Vehicle Implementation Section Manager**
 - ekeddie@arb.ca.gov